

# BENKISER

## EINBAUEMPFEHLUNG METRIX SERIE INSTALLATION RECOMMENDATION METRIX SERIES

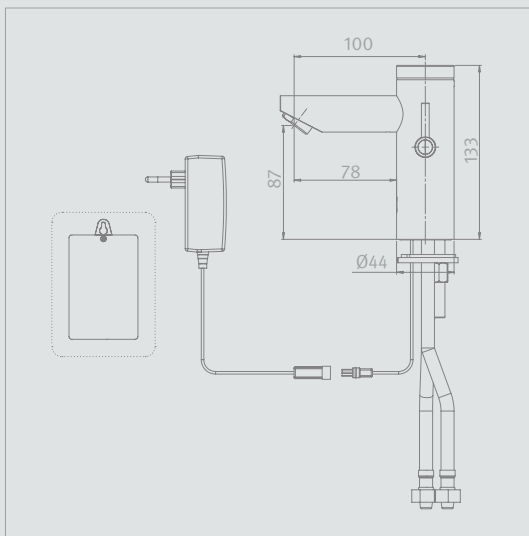

**Metrix II (Misch-) Armatur**  
1995050 | 1995053 - 1996050 | 1996053

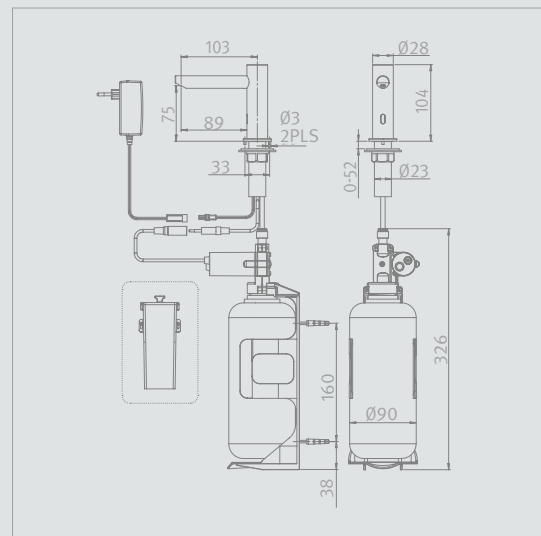

**Metrix Seifenspender**  
1991010 | 1991023

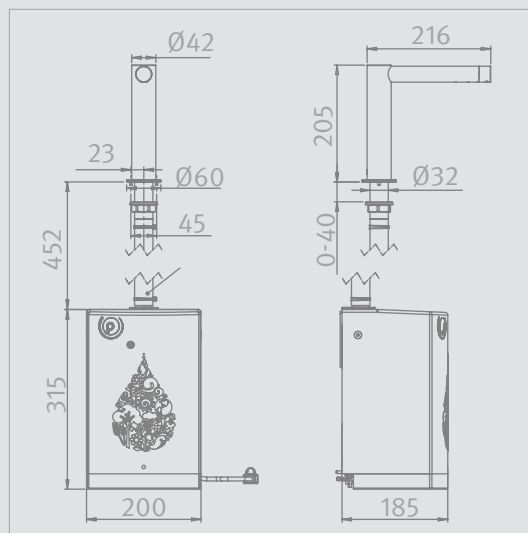

**Metrix Handtrockner**  
1990201

# EINBAUEMPFEHLUNG | INSTALLATION RECOMMENDATION

## DURCHMESSER ARMATUR | FITTING DIAMETER

1990201	Metrix Handtrockner Metrix Hand Dryer	60 mm (ohne Standing 42 mm) 60 mm (without foot ring 42 mm)
1995050   1995053 1996050   1996053	Metrix II Armatur Metrix II Faucet	44 mm
1991010   1991023	Metrix Seifenspender Metrix Soap Dispenser	38 mm (ohne Standing 28 mm) 38 mm (without foot ring 28 mm)

## BOHRLOCH | INSTALLATION HOLE

1990201	Metrix Handtrockner Metrix Hand Dryer	min. 33 mm, max. 36 mm
1995050   1995053 1996050   1996053	Metrix II Armatur Metrix II Faucet	min. 28 mm, max. 34 mm
1991010   1991023	Metrix Seifenspender Metrix Soap Dispenser	min. 26 mm, max. 30 mm

### WICHTIG | IMPORTANT

(GER) Es sollte ein Abstand von mindestens 20 cm zwischen den Mitten der Armaturenkörper eingehalten werden (bei Einbau gerade nach vorne).

(EN) Leave at least a 20 cm distance between the fittings, measured from the middle of the fitting body (for washbasins where the fittings looks straight ahead).

(GER) Breite Waschtisch: ca. 60 cm (nicht < 55 cm)

(EN) Depth Washbasin: approx. 60 cm (not < 55 cm)



# **BENKISER**

Daimlerstraße 2, D-93133 Burglengenfeld, Germany  
Tel. + 49 (0) 9471 / 600 93 0

**[www.benkiser.net](http://www.benkiser.net) | [info@benkiser.de](mailto:info@benkiser.de)**